

Two stage servoproportional directional valves

digital, with two position transducers and **zero spool overlap**, rugged design

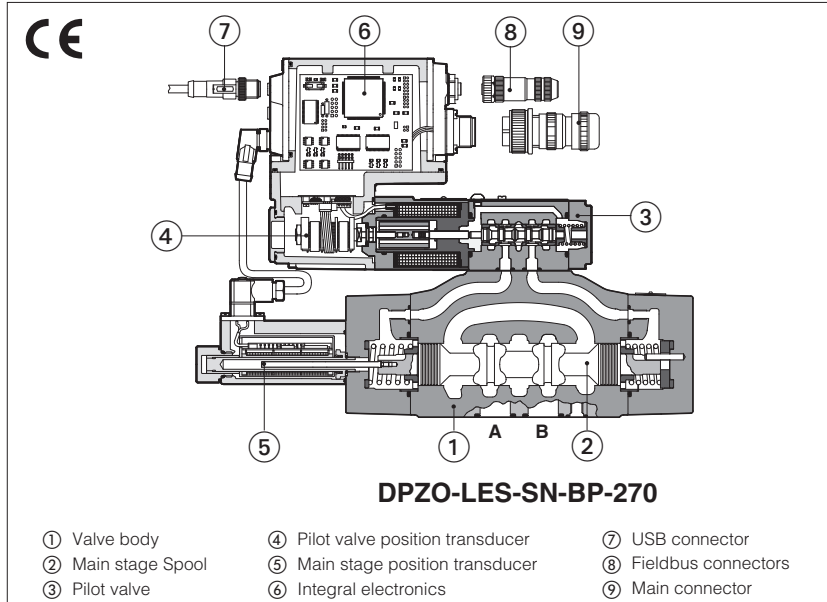

DPZO-LEB, DPZO-LES

Servoproportional two stage digital proportional valves with two LVDT position transducer and zero spool overlap for position closed loop controls.

The integral digital electronic driver performs the valve's hydraulic regulation according to the reference signal and assures valve-to-valve interchangeability thanks to the factory presetting.

Servoproportional valves are available in LEB basic execution with analog reference signals and USB port for software functional parameters setting or in LES full execution which includes also optional alternated P/Q controls and fieldbus interfaces for functional parameters setting, reference signals and real-time diagnostics.

Digital LEZ version (tech table FS230) integrates the closed loop axis control functions, while LEB and LES versions can be used in combination with remote Z-ME-KZ digital axis controller (see tech table G340).

Size: **10 to 35**
 Max flow: **180 to 3500 l/min**
 Max pressure: **350 bar**

1 MODEL CODE for STANDARD SPOOLS

DPZO	-	L	ES	-	SN	-	NP	-	2	70	-	L	5	/	*	/	*	/	*
Two stage proportional directional valve																		Seals material, see sect. 5, 6: - = NBR PE = FKM BT = HNBR	
L = closed-loop two LVDT transducer																		Series number	

Integral digital drivers:
EB = basic (1)
ES = full

Alternated P/Q controls - see section 4
SN = none
SP = pressure control (1 pressure transducer)
SF = force control (2 pressure transducers)
SL = force control (1 load cell)

Fieldbus interfaces USB port always present:
NP = Not present (1)
BC = CANopen **BP** = PROFIBUS DP
EH = EtherCAT **EW** = POWERLINK

Valve size ISO 4401:
 1 = 10 2 = 16 4 = 25 4M = 27 6 = 32 8 = 35

Configuration:

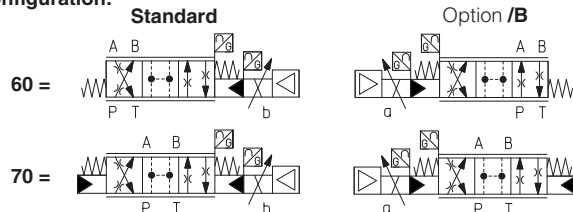

Spool type - regulating characteristics:

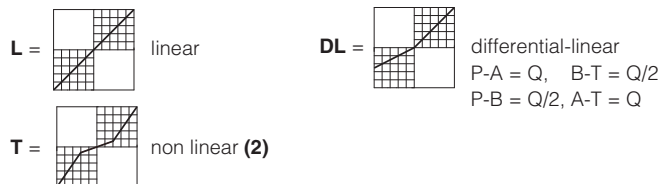

Hydraulic options, see section 10:

B = solenoid, integral electronics and position transducer at side of port B of the main stage
D = internal drain
E = external pilot (through port X)
G = pressure reducing valve for piloting - standard for size 10

Electronic options, see sections 11

I = current reference input and monitor 4÷20 mA (omit for standard voltage reference input and monitor ±10 V)

Only for SN (3):

F = fault signal
Q = enable signal
Z = double power supply (4), enable, fault and monitor signals - 12 pin connector

Only for SP, SF, SL:

C = current feedback for remote transducer(s)

Spool size	3 (L)	5 (L,DL)	5 (L)	5 (T)
DPZO-1	-	100	-	-
DPZO-2	160	250	-	190
DPZO-4	-	480	-	-
DPZO-4M	-	550	-	-
DPZO-6	-	-	640	-
DPZO-8	-	-	1200	-

Nominal flow (l/min) at Δp 10bar P-T

(1) LEB available only in version SN-NP
 (3) F, Q, Z options are standard for SP, SF, SL

(2) only for configuration 70
 (4) double power supply only for LES

2 GENERAL NOTES

DPZO-LEB, LES proportional valves are CE marked according to the applicable Directives (e.g. Immunity/Emission EMC Directive and Low Voltage Directive). Installation, wirings and start-up procedures must be performed according to the general prescriptions shown in table F003 and in the installation notes supplied with relevant components. The electrical signals of the valve (e.g. monitor signals) must not be directly used to activate safety functions, like to switch-ON/OFF the machine's safety components, as prescribed by the European standards (Safety requirements of fluid technology systems and components-hydraulics, EN-982).



WARNING

To avoid overheating and possible damage of the electronic driver, the valves must be never energized without hydraulic supply to the pilot stage. In case of prolonged pauses of the valve operation during the machine cycle, it is always advisable to disable the driver (option /Q or /Z)

A safety fuse 2,5 A installed on 24VDC power supply of each valve is always recommended, see also Power supply note at sections [11](#)

3 AXIS CONTROLLER

Digital servoproportional with integral electronics **LEZ** include valve's driver plus axis controller, performing position closed loop of any hydraulic actuator equipped with analog, encoder or SSI position transducer. S* option add alternated P/Q control to the basic position ones.

For detailed information about integral axis controller see tech table **FS230**.

Atos also supply complete servoactuators integrating servocylinder, digital servoproportional valve and axis controller, fully assembled and tested. For more information consult Atos Technical Office.

4 ALTERNATED P/Q CONTROLS - only for LES

S* options add the closed loop control of pressure (**SP**) or force (**SF** and **SL**) to the basic functions of proportional directional valves flow regulation. A dedicated algorithm alternates pressure (force) depending on the actual hydraulic system conditions.

An additional connector is available for transducers to be interfaced to the valve's driver (1 pressure transducer for SP, 2 pressure transducers for SF or 1 load cell for SL). Main 12 pin connector is the same as /Z option plus two analog signals specific for the pressure (force) control.

The alternated P/Q controls are specific for valve configuration 73, optional spools type Q5 and V9 recommended, see section [2](#)

For detailed information and connector wiring of options SP, SF, SL see tech table **GS212**.

5 FIELDBUS - only for LES

Fieldbus allows the direct communication of the proportional valve with machine control unit for digital reference signal, diagnostics and settings of functional parameters. Analog reference signal remain available on the main connector for quick commissioning and maintenance.

For detailed information about fieldbus features and specification see tech table **GS510**.

6 CENTRAL SAFETY REST POSITION OF ZERO SPOOL OVERLAP - configuration 70

In absence of electric power supply (+24 VDC), the valve main spool is moved by the springs force to the **central safety rest position** characterized by a small offset of about 1% to 6% of the total stroke in P-B / A-T configuration.

This is specifically designed to avoid that in case of accidental interruption of the electrical power supply to the valve, the actuator moves towards an undefined direction (due to the tolerances of the zero overlap spool), with potential risk of damages or personnel injury.

Thanks to the **central safety rest position** the actuator movement is suddenly stopped and it is recovered at very low speed towards the direction corresponding to the P-B/ A-T connection.

The main spool moves to the closed loop control position (zero overlap) when the pilot pressure is activated, the valve is fed with power supply +24 Vdc and reference input = 0V (or 12 mA for option /I) is applied to the driver.

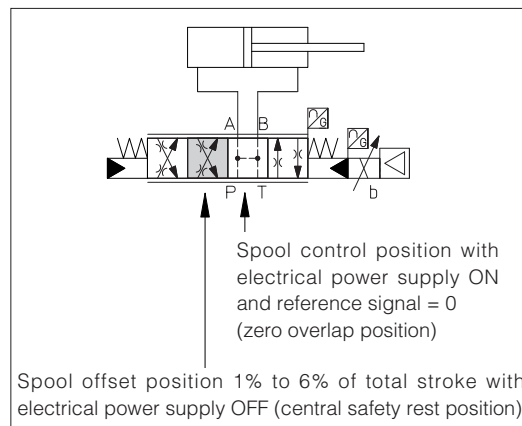

7 MAIN CHARACTERISTICS

Assembly position	Any position			
Subplate surface finishing	Roughness index, Ra 0,4 flatness ratio 0,01/100 (ISO 1101)			
MTTFd valves according to EN ISO 13849	75 years, see technical table P007			
Ambient temperature range	standard execution = -20°C ÷ +70°C /BT option = -40°C ÷ +60°C			
Storage temperature range	standard execution = -20°C ÷ +70°C /BT option = -40°C ÷ +70°C			
Coil resistance R at 20°C	3 ÷ 3,3 Ω			
Max. solenoid current	2,6 A			
Max. power	50 Watt			
Insulation class	H (180°) Due to the occurring surface temperatures of the solenoid coils, the European standards ISO 13732-1 and EN982 must be taken into account			
Protection degree to DIN EN60529	IP66/67 with mating connectors			
Tropicalization	Tropical coating on electronics PCB			
Duty factor	Continuous rating (ED=100%)			
EMC, climate and mechanical load	See technical table G004			
Communication interface	USB Atos ASCII coding	CANopen EN50325-4 + DS408	PROFIBUS DP EN50170-2/IEC61158	EtherCAT, POWERLINK IEC 61158
Communication physical layer	not insulated USB 2.0 + USB OTG	optical insulated CAN ISO11898	optical insulated RS485	Fast Ethernet, insulated 100 Base TX

Valve model	DPZO-*-1	DPZO-*-2			DPZO-*-4	DPZO-*-4M	DPZO-*-6	DPZO-*-8
Pressure limits [bar]	ports P, A, B, X = 350; T = 250 (10 for option /D); Y = 10;							
Spool type	L5, DL5	L3	L5, DL5	T5	L5, DL5		L5	
Nominal flow [l/min] (1) Δp P-T Δp = 10 bar	100	160	250	190	480	550	640	1200
Δp = 30 bar	160	270	430	330	830	950	1100	2000
Max permissible flow [l/min]	180	400	550	550	1000	1100	1600	3500
Piloting pressure [bar]	min. = 25; max = 350 (option /G advisable for pilot pressure > 200 bar)							
Piloting volume [cm³/min]	1,4	3,7			9	11,3	21,6	39,8
Piloting flow (2) [l/min]	3,5	9			18	20	19	24
Leakage Pilot [cm³/min] (3) Main stage [l/min]	100/300	150/450			200/600	200/600	900/2800	900/2800
Response time (4) [ms] (0-100% step signal)	< 25	< 25			< 30	< 35	< 80	< 100
Hysteresis	≤ 0,1 [%of max regulation]							
Repeatability	± 0,1 [%of max regulation]							
Thermal drift	zero point displacement < 1% at ΔT = 40°C							

Notes:

above performance data refer to valves coupled with Atos electronic drivers, see section 9.

(1) For different Δp, the max flow is in accordance to the diagrams in section 10.2

(2) with step reference input signal 0 ÷ 100 %

(3) at p = 100/350 bar

(4) see diagrams in section 10.3

8 SEALS AND HYDRAULIC FLUID

Seals, recommended temperature fluid	NBR seals (standard) = -20°C ÷ +60°C, with HFC hydraulic fluids = -20°C ÷ +50°C FKM seals (/PE option) = -20°C ÷ +80°C HNBR seals (/BT option) = -40°C ÷ +60°C, with HFC hydraulic fluids = -40°C ÷ +50°C		
Recommended viscosity	20 ÷ 100 mm²/s - max allowed range 15 ÷ 380 mm²/s		
Fluid contamination class	ISO 4406 class 20/18/15 NAS 1638 class 9, in line filters of 10 μm (β10 ≥ 75 recommended)		
Hydraulic fluid	Suitable seals type	Classification	Ref. Standard
Mineral oils	NBR, FKM, HNBR	HL, HLP, HLPD, HVLP, HVLPD	DIN 51524
Flame resistant without water	FKM	HFDR, HFDR	ISO 12922
Flame resistant with water	NBR, HNBR	HFC	

Note: For other fluids not included in above table, consult our technical office

9 ELECTRONIC DRIVERS - for main and communication connector see sections 14, 15

Valve model	LEB	LES	LES-SP, SF, SL	LEZ
Drivers model	E-RI-LEB-N	E-RI-LES-N	E-RI-LES-S	E-RI-LEZ
Type	Digital			
Format	Integral to valve			
Data sheet	GS208	GS210	GS212	FS230

10 DIAGRAMS (based on mineral oil ISO VG 46 at 50 °C)

10.1 Regulation diagrams (values measure at Δp 10 bar P-T)

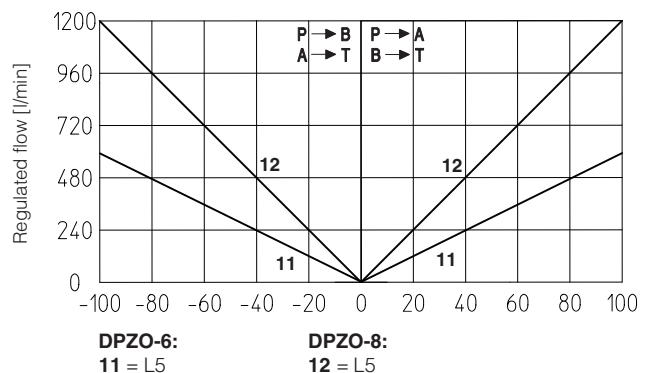
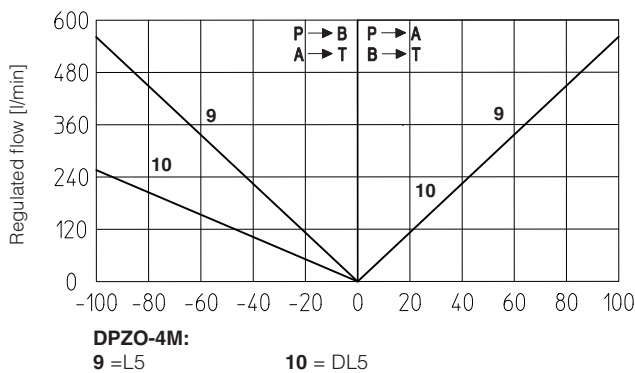
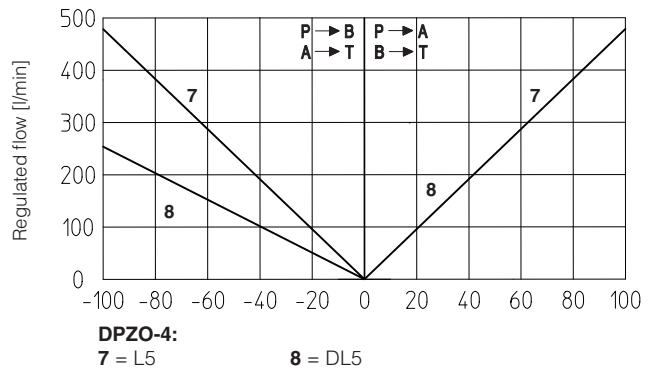
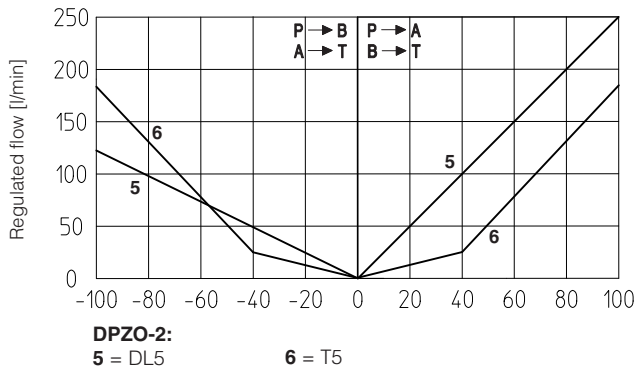
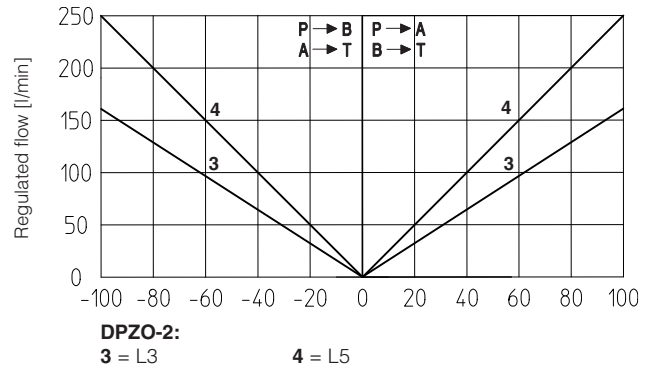
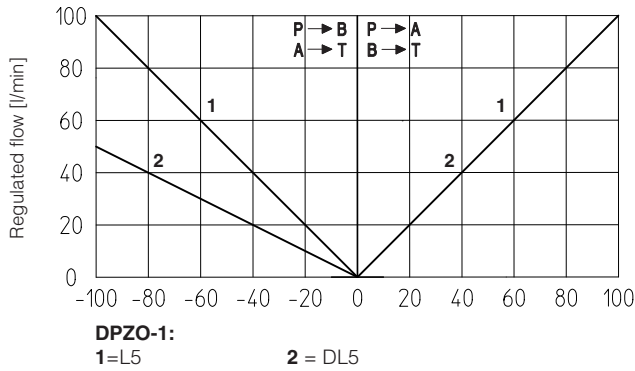

10.2 Flow / Δp diagram - stated at 100% of spool stroke

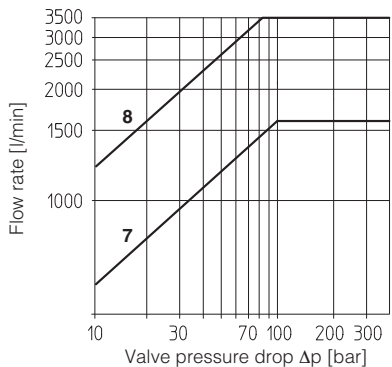
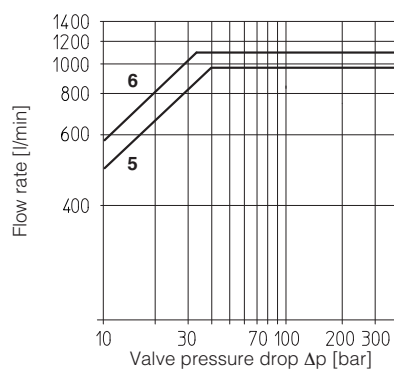
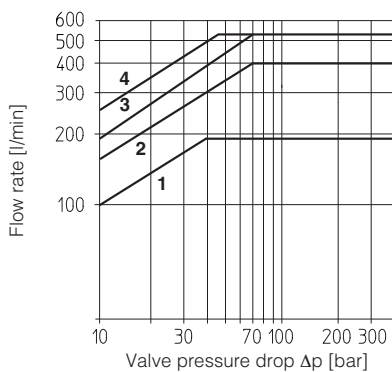

- | | | |
|--------------------------------------|---------------------------------------|--------------------------|
| DPZO-1:
1 = spools L5, DL5 | DPZO-4:
5 = spools L5, DL5 | DPZO-6:
7 = L5 |
| DPZO-2:
2 = spools L3 | DPZO-4M:
6 = spools L5, DL5 | DPZO-8:
8 = L5 |
| DPZO-3:
3 = spool T5 | | |
| DPZO-4:
4 = spools L5, DL5 | | |

Note: Hydraulic configuration vs. reference signal for configurations 60 and 70 (standard and option/B)

Reference signal	0 \div +10 V	} P \rightarrow A / B \rightarrow T
Reference signal	0 \div -10 V	
	4 \div \pm 12 mA	} P \rightarrow B / A \rightarrow T

10.3 Response time

The response times in below diagrams are measured at different steps of the reference input signal. They have to be considered as average values. For the valves with digital electronics the dynamics performances can be optimized by setting the internal software parameters.

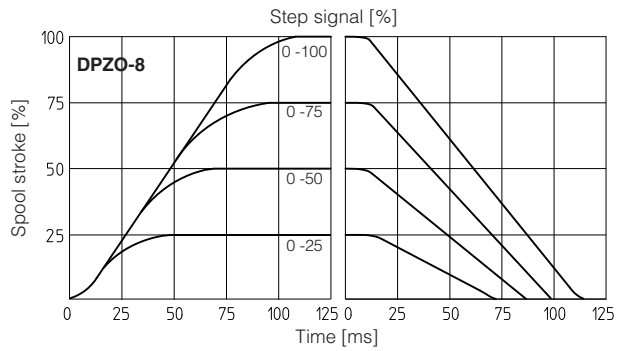
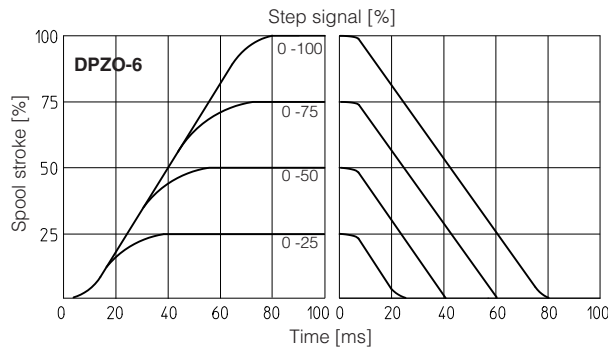
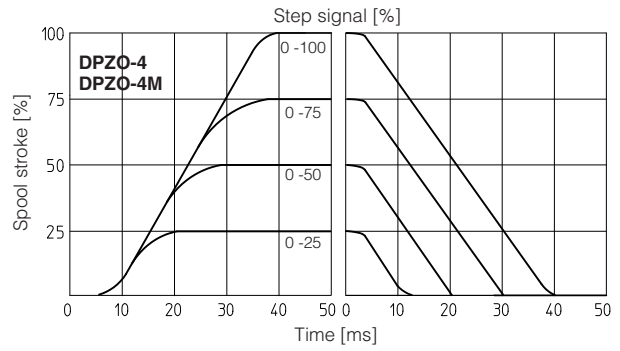
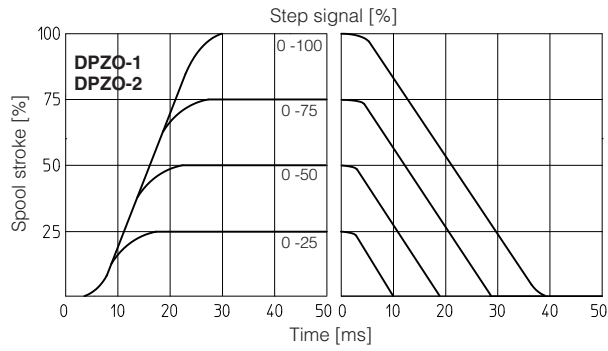

10.4 Bode diagrams

Stated at nominal hydraulic conditions.

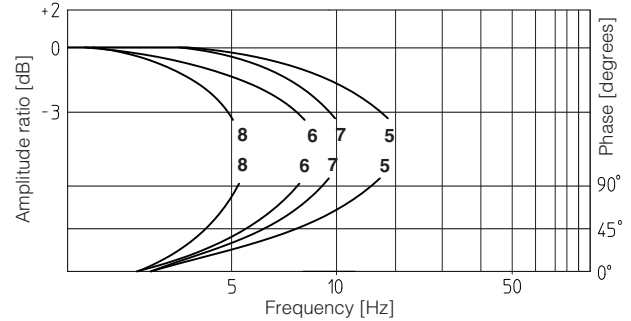
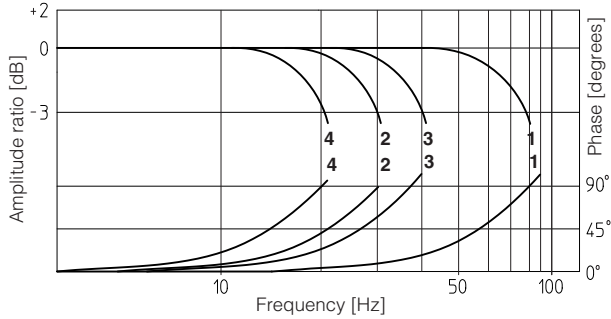

- | | |
|-------------------|---------------------|
| 1 = DPZO-1 } ± 5% | 2 = DPZO-1 } ± 100% |
| DPZO-2 } ± 5% | DPZO-2 } ± 100% |
| 3 = DPZO-4 } ± 5% | 4 = DPZO-4 } ± 100% |
| DPZO-4M } ± 5% | DPZO-4M } ± 100% |
| 5 = DPZO-6 ± 5% | 6 = DPZO-6 ± 100% |
| 7 = DPZO-8 ± 5% | 8 = DPZO-8 ± 100% |

10.5 Pressure gain

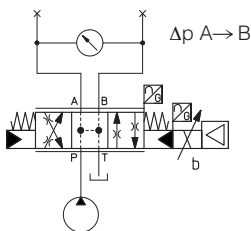

- 9 = DPZO-1
10 = DPZO-2
DPZO-4
DPZO-4M
DPZO-6
DPZO-8

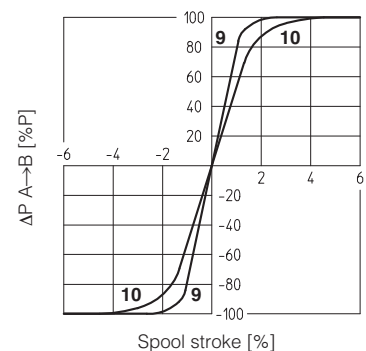

11 HYDRAULIC OPTIONS

11.1 Option /B

Solenoid, integral electronics and position transducer at side of port B of the main stage.
For hydraulic configuration vs reference signal, see section 10.1

11.2 Option /G

Pressure reducing valve ③ with fixed setting, installed between pilot valve and main body. Reduced pressure setting:

40 bar for DPZO-1 and DPZO-2

100 bar for DPZO-4(M), DPZO-6 and DPZO-8

It is advisable for valves with internal pilot in case of system pressure higher than 200 bar.

Pressure reducing valve ③ is standard for DPZO-1, for other sizes add /G option.

11.3 Pilot and drain configuration

The pilot / drain configuration can be modified as shown in the functional scheme here aside, for detailed view of plugs position, see section 17

The valve's standard configuration provides internal pilot and external drain.

For different pilot / drain configuration select:

Option /E External pilot (through port X)

Option /D Internal drain (through port T)

FUNCTIONAL SCHEME - example of configuration 70

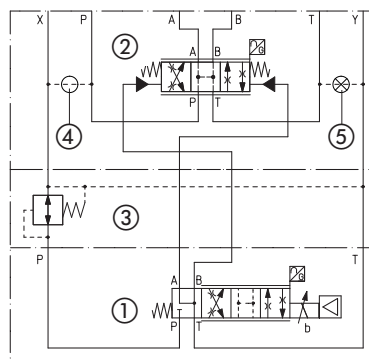

- ① Pilot valve
- ② Main stage
- ③ Pressure reducing valve
- ④ Plug to be added for external pilot trough port X
- ⑤ Plug to be removed for internal drain through port T

12 ELECTRONIC OPTIONS

Standard driver execution provides on the 7 pin main connector:

Power supply - 24 VDC must be appropriately stabilized or rectified and filtered; **2,5 A** fuse time lag is required in series to each driver power supply. Apply at least a 10000 μ F/40 V capacitance to single phase rectifiers or a 4700 μ F/40 V capacitance to three phase rectifiers

Reference input signal - analog differential input with ± 10 VDC nominal range (pin D, E), proportional to desired valve spool position

Monitor output signal - analog output signal proportional to the actual valve's spool position with ± 10 VDC nominal range

Note: a minimum booting time between 400 and 800 ms has been considered from the driver energizing with the 24 Vdc power supply before the valve has been ready to operate. During this time the current to the valve coils is switched to zero.

12.1 Option /F

It provides a Fault output signal in place of the Monitor output signal, to indicate fault conditions of the driver (cable interruption of spool transducers or reference signal - for /I option): Fault presence corresponds to 0 VDC, normal working corresponds to 24 Vdc

12.2 Option /I

It provides 4 \div 20 mA current reference and monitor signals, instead of the standard ± 10 V.

Input signal can be reconfigured via software selecting between voltage and current, within a maximum range of ± 10 V or ± 20 mA.

It is normally used in case of long distance between the machine control unit and the valve or where the reference signal can be affected by electrical noise; the valve functioning is disabled in case of reference signal cable breakage.

12.3 Option /Q

It provides the possibility to enable or disable the valve functioning without cutting the power supply (the valve functioning is disabled but the driver current output stage is still active). To enable the driver supply a 24 VDC on the enable input signal.

12.4 Option /Z

It provides, on the 12 pin main connector, the following additional features:

Enable Input Signal

To enable the driver, supply 24 VDC on pin 3 referred to pin 2: when the Enable signal is set to zero the valve functioning is disabled (zero current to the solenoid) but the driver current output stage is still active.

Fault Output Signal

Fault output signal indicates fault conditions of the driver (solenoid short circuits/not connected, reference signal cable broken for 4 \div 20mA input, etc.). Fault presence corresponds to 0 VDC, normal working corresponds to 24 VDC (pin 11 referred to pin 2): Fault status is not affected by the Enable input signal

Power supply for driver's logics and communication - only for LES

Separated power supply for the solenoid (pin 1, 2) and for the digital electronic circuits (pin 9, 10).

Cutting solenoid power supply allows to interrupt the valve functioning but keeping energized the digital electronics thus avoiding fault conditions of the machine fieldbus controller. This condition aids to realize safety systems in compliance with European Norms EN13849-1 (ex EN954-1).

12.5 Options /C - only for SP, SF, SL

Option /C is available to connect pressure (force) transducers with 4 \div 20 mA current output signal, instead of the standard ± 10 V.

Input signal can be reconfigured via software selecting between voltage and current, within a maximum range of ± 10 V or ± 20 mA.

12.6 Possible combined options

For SN: /FI, /IQ and /IZ

For SP, SF, SL: /CI

13 ELECTRONIC CONNECTIONS AND LEDS

13.1 Main connector signals - 7 pin - standard, /F and /Q options (A1)

PIN	Standard	/Q	/F	TECHNICAL SPECIFICATIONS	NOTES
A	V+			Power supply 24 Vdc	Input - power supply
B	V0			Power supply 0 Vdc	Gnd - power supply
C	AGND		AGND	Analog ground	Gnd - analog signal
		ENABLE		Enable (24 Vdc) or disable (0 Vdc) the valve, referred to V0	Input - on/off signal
D	Q_INPUT+			Flow reference input signal: ± 10 Vdc / ± 20 mA maximum range Defaults are ± 10 Vdc for standard and $4 \div 20$ mA for /I option	Input - analog signal Software selectable
E	INPUT-			Negative reference input signal for Q_INPUT+	Input - analog signal
F	Q_MONITOR referred to: AGND V0			Flow monitor output signal: ± 10 Vdc / ± 20 mA maximum range Defaults are ± 10 Vdc for standard and $4 \div 20$ mA for /I option	Output - analog signal Software selectable
			FAULT	Fault (0 Vdc) or normal working (24 Vdc)	Output - on/off signal
G	EARTH			Internally connected to the driver housing	

13.2 Main connector signals - 12 pin - /Z option and SP, SF, SL (A2)

PIN	LEB-SN /Z	LES-SN /Z	LES-SP, SF, SL BC, BP, EH, EW NP	TECHNICAL SPECIFICATIONS	NOTES
1	V+			Power supply 24 Vdc	Input - power supply
2	V0			Power supply 0 Vdc	Gnd - power supply
3	ENABLE referred to: V0 VL0 VL0 V0			Enable (24 Vdc) or disable (0 Vdc) the valve	Input - on/off signal
	Q_INPUT+			Flow reference input signal: ± 10 Vdc / ± 20 mA maximum range Defaults are ± 10 Vdc for standard and $4 \div 20$ mA for /I option	Input - analog signal Software selectable
5	INPUT-			Negative reference input signal for Q_INPUT+ and F_INPUT+	Input - analog signal
6	Q_MONITOR referred to: AGND VL0 VL0 V0			Flow monitor output signal: ± 10 Vdc / ± 20 mA maximum range Defaults are ± 10 Vdc for standard and $4 \div 20$ mA for /I option	Output - analog signal Software selectable
	AGND			Analog ground	Gnd - analog signal
7		NC		Do not connect	
			F_INPUT+	Pressure/Force reference input signal: ± 10 Vdc / ± 20 mA maximum range Defaults are ± 10 Vdc for standard and $4 \div 20$ mA for /I option	Input - analog signal Software selectable
8	R_ENABLE			Repeat enable, output repeter signal of enable input, referred to V0	Output - on/off signal
		NC		Do not connect	
			F_MONITOR referred to: VL0 V0	Pressure/Force monitor output signal: ± 10 Vdc / ± 20 mA maximum range Defaults are ± 10 Vdc for standard and $4 \div 20$ mA for /I option	Output - analog signal Software selectable
	NC			Do not connect	
9		VL+		Power supply 24 Vdc for driver's logic and communication	Input - power supply
			D_IN0	Multiple pressure/force PID selection, referred to V0	Input - analog signal
10	NC			Do not connect	
		VL0		Power supply 0 Vdc for driver's logic and communication	Gnd - power supply
			D_IN1	Multiple pressure/force PID selection (not available for SF), referred to V0	Input - on/off signal
11	FAULT referred to: V0 VL0 VL0 VL0			Fault (0 Vdc) or normal working (24 Vdc)	Output - on/off signal
	EARTH			Internally connected to the driver housing	

Note: do not disconnect VL0 before VL+ when the driver is connected to PC USB port

13.3 Communications connectors (B) - (C)

(B) USB connector - M12 - 5 pin always present		
PIN	SIGNAL	TECHNICAL SPECIFICATION (1)
1	+5V_USB	Supply for external USB Flash Drive
2	ID	USB Flash Drive identification
3	GND_USB	Signal zero data line
4	D-	Data line -
5	D+	Data line +

(C1) (C2) BP fieldbus execution, connector - M12 - 5 pin		
PIN	SIGNAL	TECHNICAL SPECIFICATION (1)
1	+5V	Termination supply signal
2	LINE-A	Bus line (high)
3	DGND	Data line and termination signal zero
4	LINE-B	Bus line (low)
5	SHIELD	

Notes: (1) shield connection on connector's housing is recommended

(C1) (C2) BC fieldbus execution, connector - M12 - 5 pin		
PIN	SIGNAL	TECHNICAL SPECIFICATION (1)
1	CAN_SHLD	Shield
2	not used	(C1) - (C2) pass-through connection (2)
3	CAN_GND	Signal zero data line
4	CAN_H	Bus line (high)
5	CAN_L	Bus line (low)

(C1) (C2) EH, EW fieldbus execution, connector - M12 - 4 pin		
PIN	SIGNAL	TECHNICAL SPECIFICATION (1)
1	TX+	Transmitter
2	RX+	Receiver
3	TX-	Transmitter
4	RX-	Receiver
Housing	SHIELD	

(2): pin 2 can be fed with external +5V supply of CAN interface

13.4 Remote pressure/force transducer connector - M12 - 5 pin - only for SP, SF, SL (D)

PIN	SIGNAL	TECHNICAL SPECIFICATION	Single transducer (1)		Double transducers (1)	
			Voltage	Current	Voltage	Current
1	VF +24V	Power supply +24Vdc	Connect	Connect	Connect	Connect
2	TR1	1st signal transducer: ± 10 Vdc / ± 20 mA maximum range, software selectable Defaults are ± 10 Vdc for standard and $4 \div 20$ mA for /C option	Connect	Connect	Connect	Connect
3	AGND	Common GND for transducer power and signals	Connect	/	Connect	/
4	TR2	2nd signal transducer: ± 10 Vdc / ± 20 mA maximum range, software selectable Defaults are ± 10 Vdc for standard and $4 \div 20$ mA for /C option	/	/	Connect	Connect
5	NC	Not connect	/	/	/	/

Note (1) single/double transducer configuration is software selectable

13.5 Connections layout

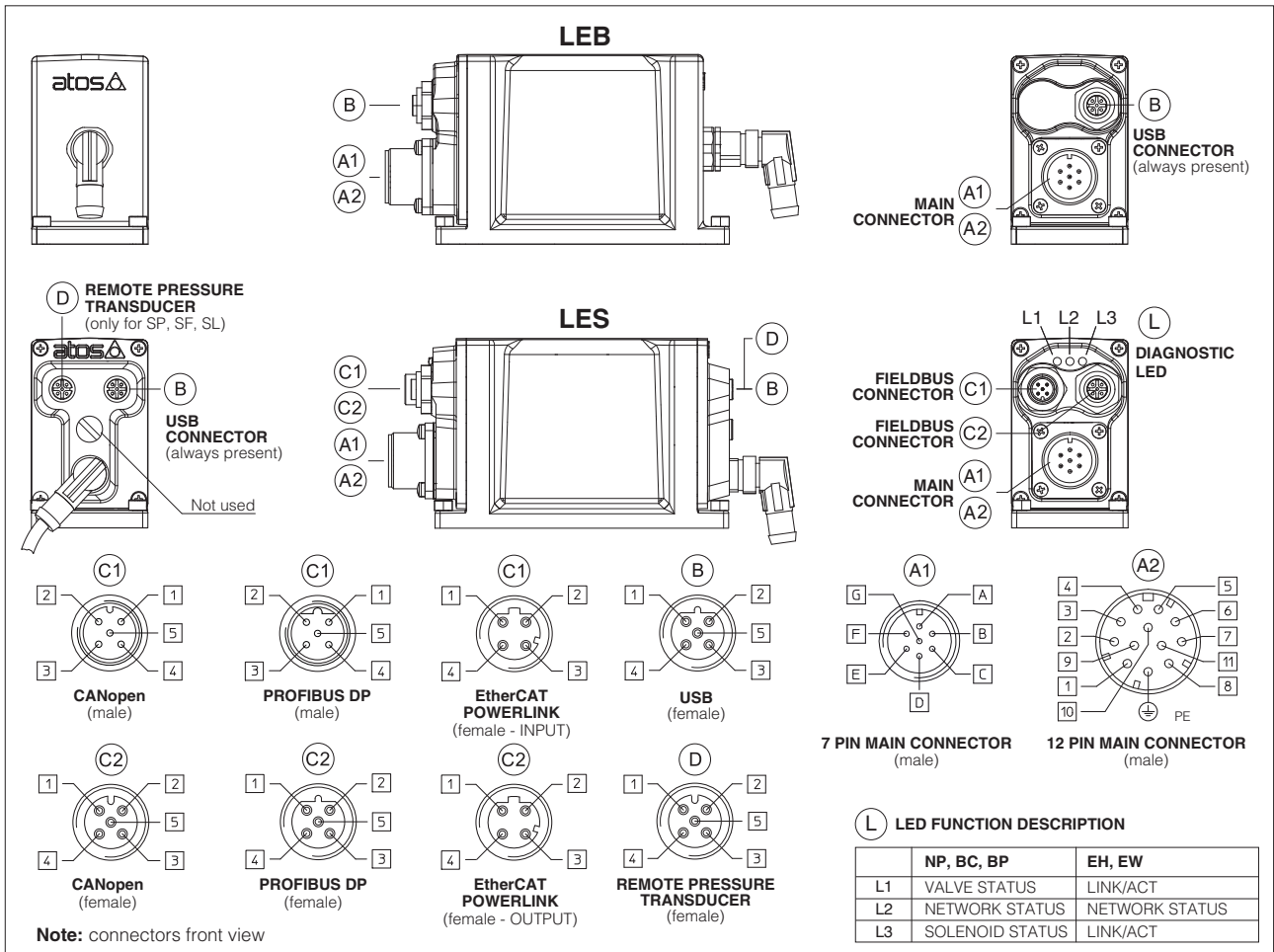

14 CONNECTORS

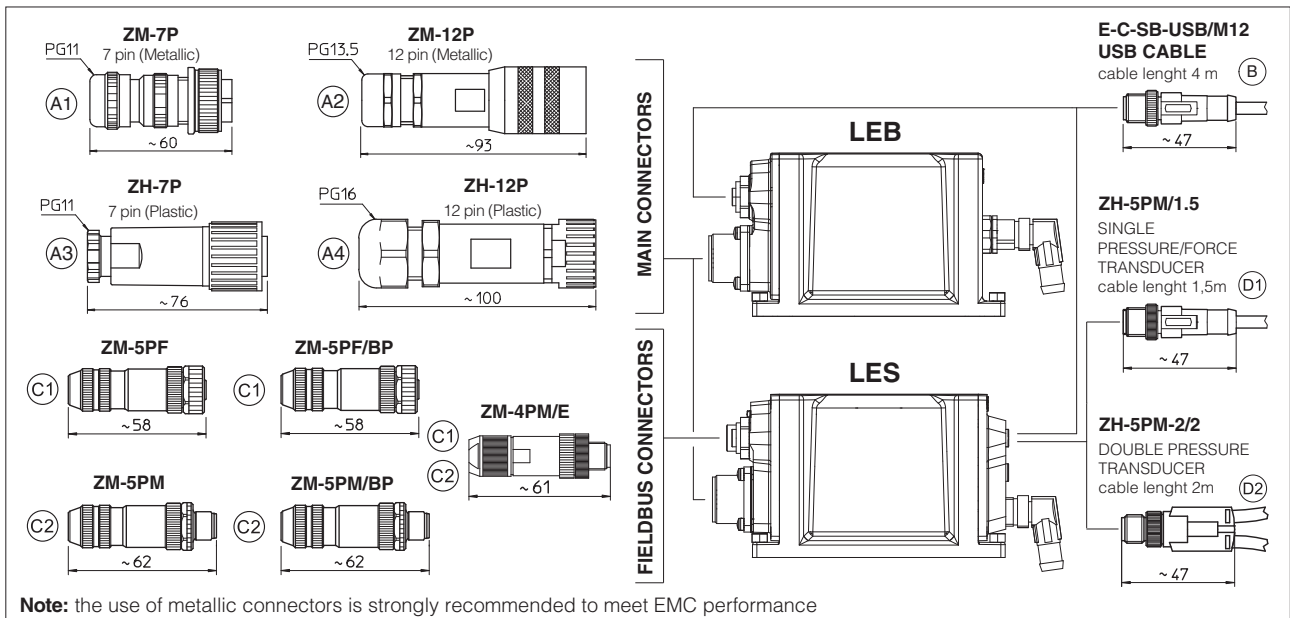

15 MODEL CODES OF MAIN CONNECTORS AND COMMUNICATION CONNECTORS - to be ordered separately

VALVE VERSION	LEB LES	LEB /Z LES /Z	BC - CANopen	BP - PROFIBUS DP	EH - EtherCat EW - POWERLINK	P/Q controls SP, SL, SF
CONNECTOR CODE	ZM-7P (A1)	ZM-12P (A2)	ZM-5PF (C1)	ZM-5PF/BP (C1)	ZM-4PM/E (C1)	ZH-5PM/1.5 (1) (D1)
	ZH-7P (A3)	ZH-12P (A4)	ZM-5PM (C2)	ZM-5PM/BP (C2)	ZM-4PM/E (C2)	ZH-5PM-2/2 (2) (D2)
PROTECTION DEGREE	IP67					
DATA SHEET	GS208, GS210, GS212, K500					

only for LES

(1) only for SP or SL

(2) only for SF

16 PROGRAMMING TOOLS - see table **GS500**

Valve's functional parameters and configurations, can be easily set and optimized using Atos E-SW programming software connected via USB port to the digital driver. For fieldbus versions, the software permits valve's parameterization through USB port also if the driver is connected to the central machine unit via fieldbus.

The software is available in different versions according to the driver's options:

- E-SW-BASIC** support: NP (USB) PS (Serial) IR (Infrared)
E-SW-FIELDBUS support: BC (CANopen) BP (PROFIBUS DP) EH (EtherCAT)
 EW (POWERLINK)
E-SW-*/PQ support: valves with SP, SF, SL alternated control (e.g. E-SW-BASIC/PQ)

WARNING: drivers USB port is not isolated!

The use of isolator adapter is highly recommended for PC protection (see table **GS500**)

USB connection

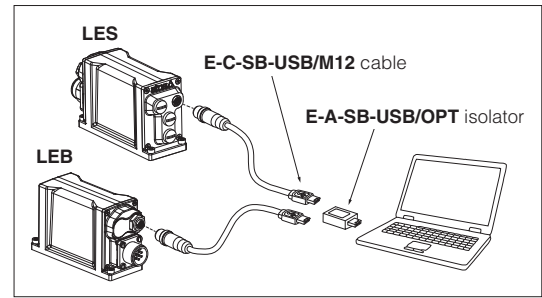

17 PLUGS LOCATION FOR PILOT/DRAIN CHANNELS

Depending on the position of internal plugs, different pilot/drain configurations can be obtained as shown below. To modify the pilot/drain configuration, proper plugs must only be interchanged. The plugs have to be sealed using loctite 270. Standard valves configuration provides internal pilot and external drain

DPZO-1 Pilot channels

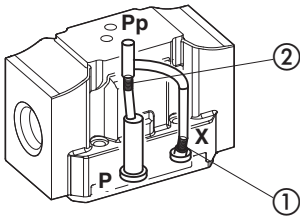

Drain channels

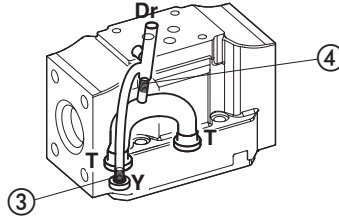

- Internal piloting:** blinded plug SP-X300F ① in X;
External piloting: blinded plug SP-X300F ② in Pp;
Internal drain: blinded plug SP-X300F ③ in Y;
External drain: blinded plug SP-X300F ④ in Dr.

DPZO-2 Pilot channels

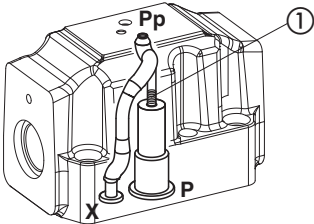

Drain channels

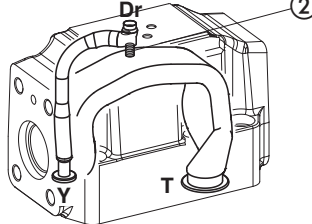

- Internal piloting:** Without blinded plug SP-X300F ①;
External piloting: Add blinded plug SP-X300F ①;
Internal drain: Without blinded plug SP-X300F ②;
External drain: Add blinded plug SP-X300F ②.

DPZO-4 Pilot channels

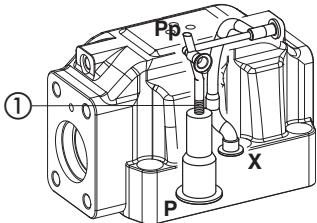

Drain channels

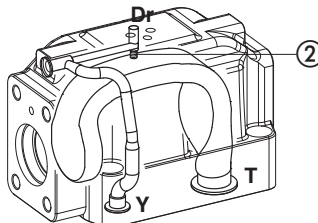

- Internal piloting:** Without blinded plug SP-X500F ①;
External piloting: Add blinded plug SP-X500F ①;
Internal drain: Without blinded plug SP-X300F ②;
External drain: Add blinded plug SP-X300F ②.

DPZO-6 Pilot channels

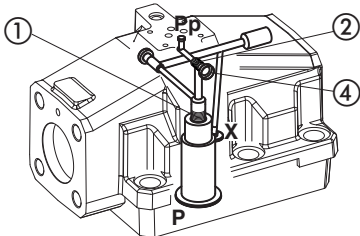

Drain channels

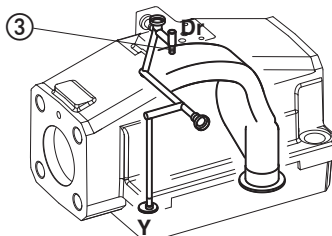

- Internal piloting:** Without plug ①;
External piloting: Add DIN-908 M16x1,5 in pos ①;
Internal drain: Without blinded plug SP-X300F ③;
External drain: Add blinded plug SP-X300F ③.

DPZO-8 Pilot channels

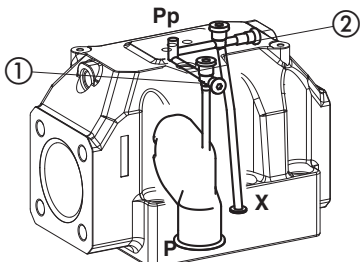

Drain channels

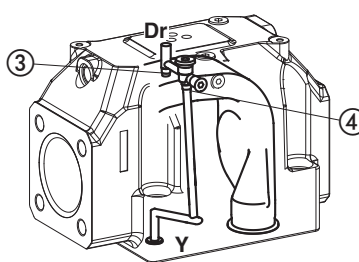

- Internal piloting:** Without plug ①;
External piloting: Add NPTF 1/8 in pos ①;
 plug NPTF 1/8 in pos ②;
Internal drain: Without plug NPTF 1/8 in pos ③;
 Add plug NPTF 1/8 in pos ④;
External drain: Add plug NPTF 1/8 in pos ③.

DPZO-LEB-*-1
DPZO-LES-*-1

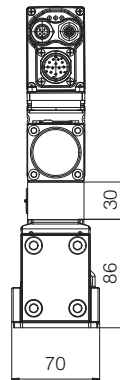
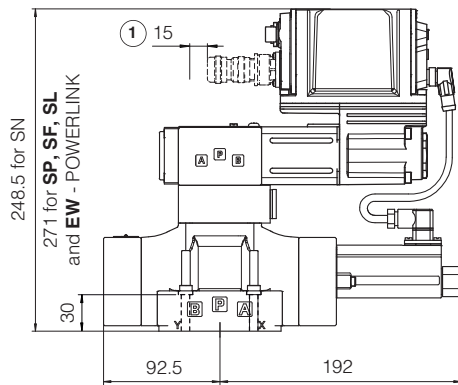

ISO 4401: 2005
Mounting surface: 4401-05-05-0-05
(see table P005)
Fastening bolts:
4 socket head screws M6x40 class 12.9
Tightening torque = 15 Nm
Seals: 5 OR 2050; 2 OR 108
Diameter of ports A, B, P, T: $\varnothing = 11$ mm;
Diameter of ports X, Y: $\varnothing = 5$ mm;

Mass 9,5 kg

DPZO-LEB-*-2
DPZO-LES-*-2

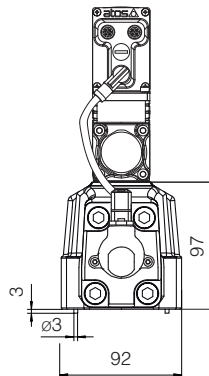
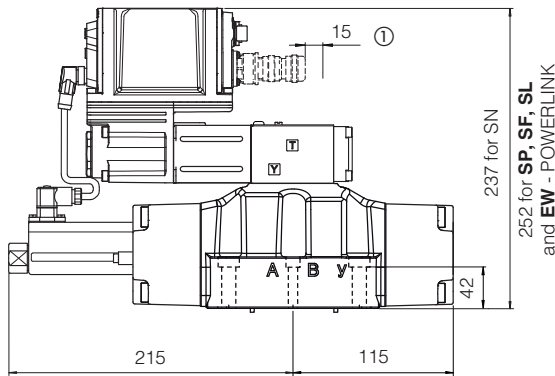

ISO 4401: 2005
Mounting surface: 4401-07-07-0-05
(see table P005)
Fastening bolts:
4 socket head screws M10x50 class 12.9
Tightening torque = 70 Nm
2 socket head screws M6x45 class 12.9
Tightening torque = 15 Nm
Seals: 4 OR 130; 2 OR 2043
Diameter of ports A, B, P, T: $\varnothing = 20$ mm;
Diameter of ports X, Y: $\varnothing = 7$ mm;

Mass 14 kg

DPZO-LEB-*-4
DPZO-LES-*-4

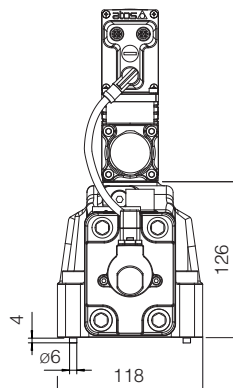
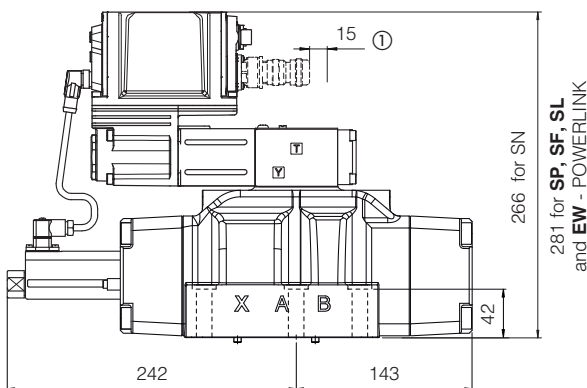

ISO 4401: 2005
Mounting surface: 4401-08-08-0-05
(see table P005)
Fastening bolts:
6 socket head screws M12x60 class 12.9
Tightening torque = 125 Nm
DPZO-4
Seals: 4 OR 4112; 2 OR 3056
Diameter of ports A, B, P, T: $\varnothing = 24$ mm;
Diameter of ports X, Y: $\varnothing = 7$ mm;

DPZO-4M
Seals: 4 OR 4131; 2 OR 3056
Diameter of ports A, B, P, T: $\varnothing = 32$ mm;
Diameter of ports X, Y: $\varnothing = 7$ mm;

Mass 19 kg

① = Space to remove the 7 or 12 pin main connector. For main and communication connectors see section 14, 15

Note: the overall height is increased by 40 mm for /G option (0,9 kg).
For option /B the proportional solenoid, the position transducer and the electronics are at side of port B of the main stage.

DPZO-LEB-*-6
DPZO-LES-*-6

ISO 4401: 2005
Mounting surface: 4401-10-09-0-05
 (see table P005)
 Fastening bolts:
 6 socket head screws M20x90 class 12.9
 Tightening torque = 600 Nm
 Diameter of ports A, B, P, T: $\varnothing = 34$ mm;
 Diameter of ports X, Y: $\varnothing = 7$ mm;
 Seals: 4 OR 144, 2 OR 3056

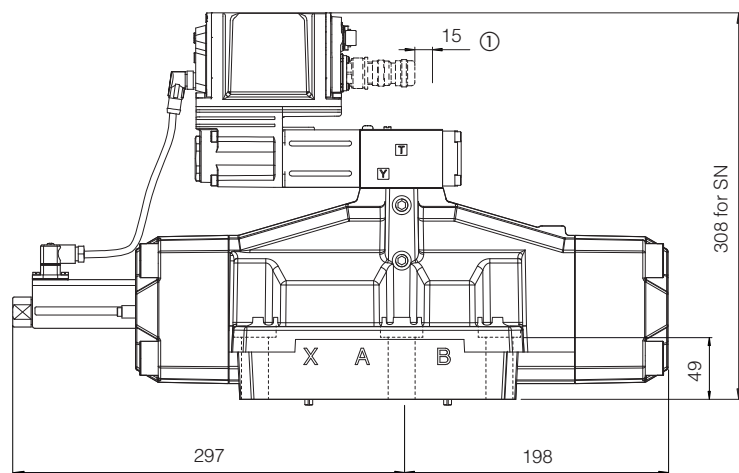

323 for **SP, SF, SL**
 and **EW** - POWERLINK

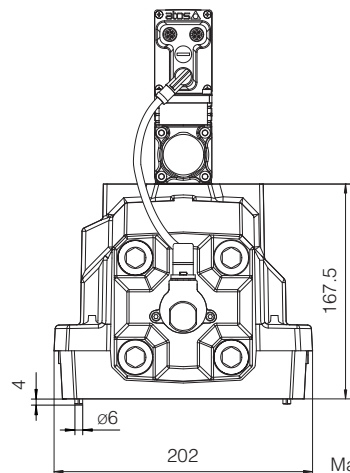

Mass 43 kg

DPZO-LEB-*-8
DPZO-LES-*-8

ISO 4401: 2005
Mounting surface: 4401-10-09-0-05
 (see table P005)
 Fastening bolts:
 6 socket head screws M20x100 class 12.9
 Tightening torque = 600 Nm
 Diameter of ports A, B, P, T: $\varnothing = 50$ mm;
 Diameter of ports X, Y: $\varnothing = 9$ mm;
 Seals: 4 OR 156, 2 OR 3056

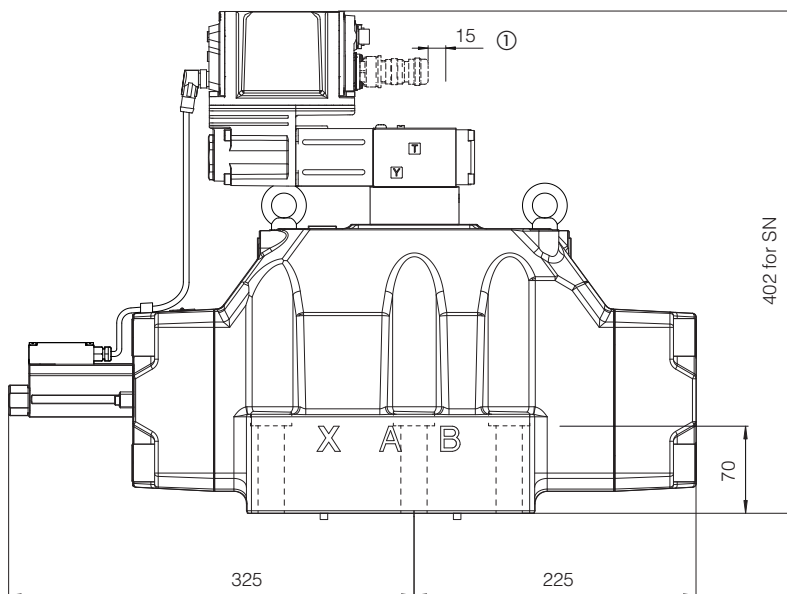

417 **SP, SF, SL**
 and **EW** - POWERLINK

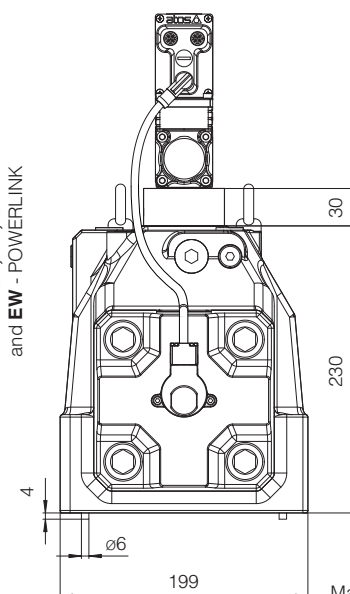

Mass 80 kg

① = Space to remove the 7 or 12 pin main connector. For main and communication connectors see section 14, 15

Note: the overall height is increased by 40 mm for /G option (0,9 kg).
 For option /B the proportional solenoid, the position transducer and the electronics are at side of port B of the main stage.

